



The Airfield, Headcorn, Kent, TN27 9HX, UK
 Tel 01622 890967 - Fax 01622 891236
 Email symbiosis.suits@btinternet.com
 www.symbiosis.suits.btinternet.co.uk

ORDER FORM - The Symbi FREE-FLY

Name _____
 Sex _____
 Address _____

 Country _____
 Tel/Fax _____
 Email _____

Office Use Only	
Date Received	
Amount Paid	
Notes	

The Symbi Free-fly suit may be ordered with either a generously cut, baggy fit or with a slimmer cut, and built from a choice of heavy 100% cotton or a lighterweight poly-cotton mix. For lightweight Free-flyers, a very lightweight Tactel may be used in certain colours (ask us for available stock). The legs may be "double lined" to create more drag if desired.

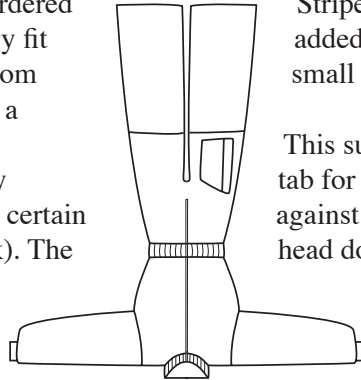

Stripes or chevrons may be added on arms and legs at a small additional cost.

This suit features a velcro tab for securing the main zip against coming undone when head down flying, secure velcro cuffs at wrist and ankle and a pocket on one leg.

COLOURS

FABRICS	100% Cotton	Poly-Cotton
COLOURS		
Black		
Dark Grey		
Light Grey		
White		
Navy Blue		
Royal Blue		
Light Blue		
Turquoise		
Jade Green		
Peppermint		
Mid Green		
Neon Yellow		
Golden Yellow		
Orange		
Red		
Bergundy		
Deep Pink		
Neon Pink		
Light Pink		
Purple		

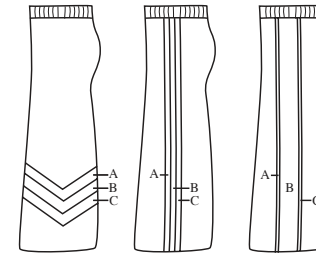
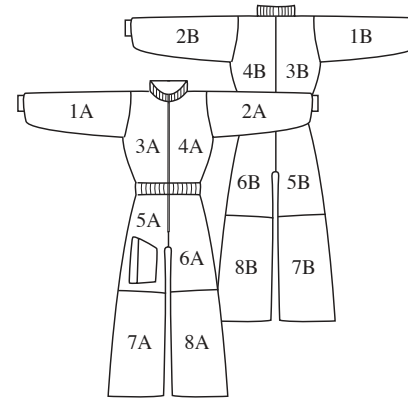

Your Colours	
1A	_____
1B	_____
2A	_____
2B	_____
3A	_____
3B	_____
4A	_____
4B	_____
5A	_____
5B	_____
6A	_____
6B	_____
7A	_____
7B	_____
8A	_____
8B	_____

Stripe Options		
1 <input type="checkbox"/>	2 <input type="checkbox"/>	3 <input type="checkbox"/>
A	_____	_____
B	_____	_____
C	_____	_____

MEASUREMENTS

Please take your measurements carefully. We are unable to make your suit fit without your correct measurements. Study the diagram to assist you. Get someone to help you and double check each measurement. Measure yourself over a T-shirt and thin trousers.

Do not add anything to your measurements.

If we receive incorrect measurements, we will have to charge for modifications.

HEIGHT _____

WEIGHT _____

SHOULDERS _____

CHEST _____

Across the back from one shoulder seam to the other. Straight tape

Widest part - Around nipple

Girls - CUP SIZE _____

ARM _____

WAIST _____

From the shoulder seam of a shirt to the bone of the wrist.

Narrowest Part

FOREARM _____

HIP _____

Widest part of the muscle.

Widest part around the buttocks

BICEP _____

THIGH _____

Widest part of muscle with the bicep relaxed.

LOWER THIGH _____

125mm above knee

CALF _____

Widest part of muscle

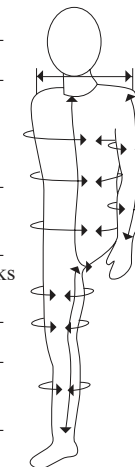

BODY _____

Be VERY careful with this measurement! Stand up straight, measure from under the crutch where the seams of your trousers meet, up the front to the collar of a close fitting T-shirt.

INSEAM _____

From the crutch to the ankle bone.

SHOE SIZE _____

(for booties only)

FREE-FLY SUIT	Baggy Fit		£161
	Slimmer Fit		
	100% Cotton		
	Poly-Cotton		
	Colour Stripes A - C		£18
	Lined Legs		£18
	Additional Pockets		£11
	Rush Order		£40
Post & Packing	UK		£10
	Europe		£15
	Outside Europe		£26
Payment for the full amount must accompany each order		TOTAL ENCLOSED	